



SAM PuttLab

...the reference in
putt training

SAM PuttLab Extended Reports

Project

Name: Examples
Description: Example Project

Player

Name: Mr. Belly Putter
Born: -
Hand: right
Handicap: -
Playing since: -

Session

Name: Belly putter
Description: imported from older version
Date: 18.02.2008

File

Name: Belly putter
Description: imported from older version
Date: 16.10.2006
Putts: 5

Technique

94.4%

Timing

81.2%

Consistency

93.4%

Overall Rating

90.6%

Aiming Report

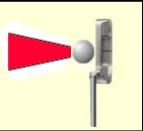

Face Aim

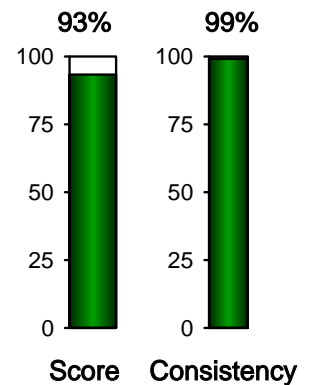
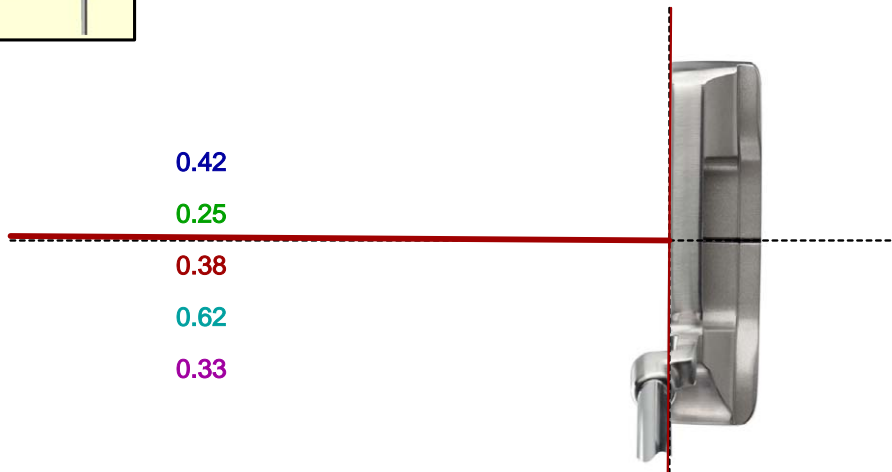

open 0.4°

Face at aim

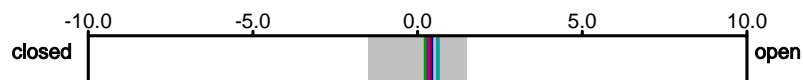

0.4° open

Face change

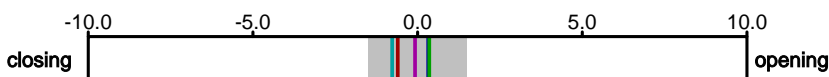

0.2° closing



Project: Examples
 Player: Mr. Belly Putter
 File: Belly putter
 Date: 16.10.2006

Direction

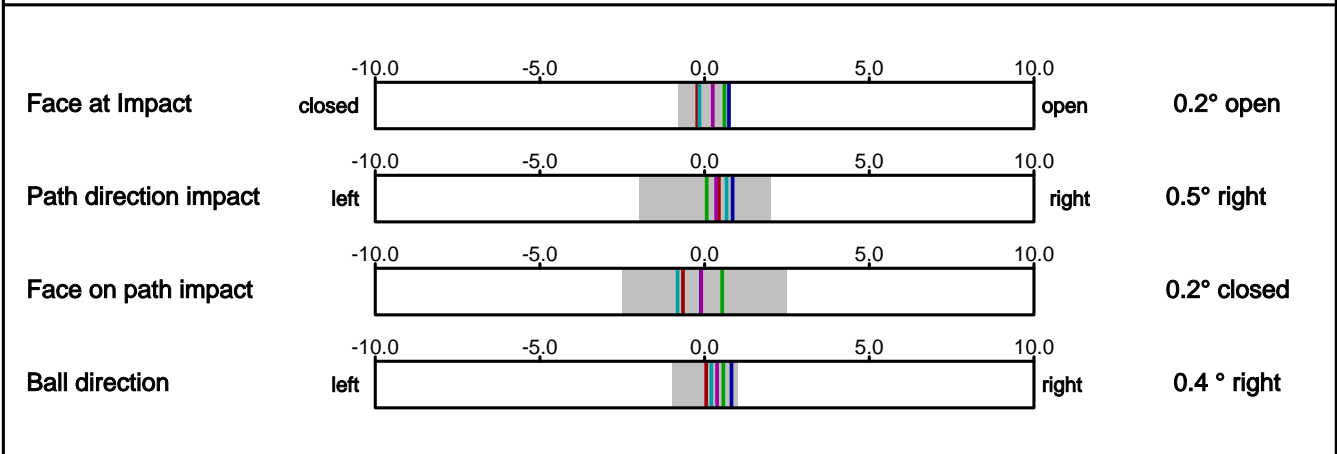
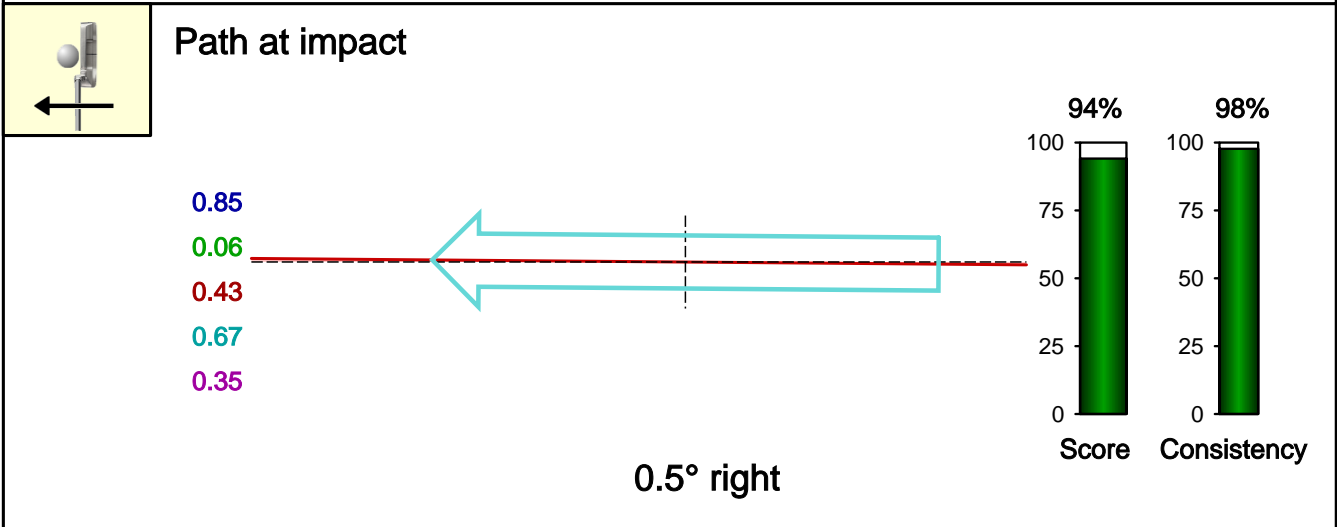
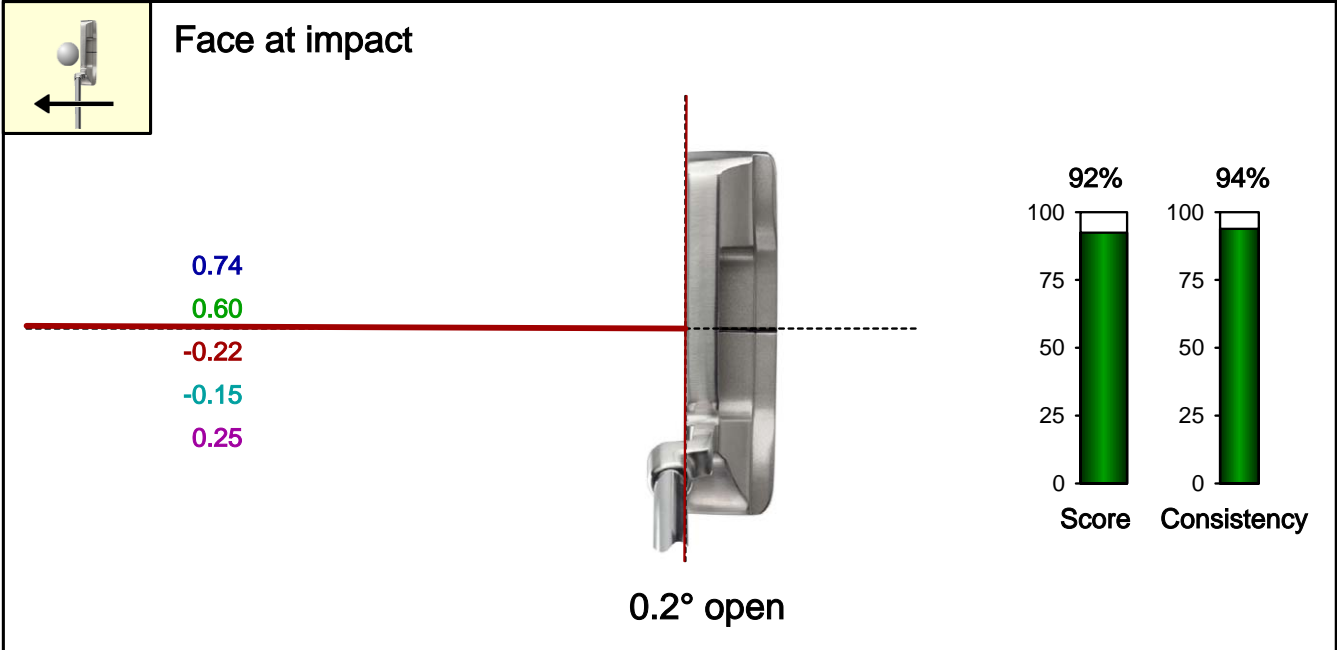



SAM PuttLab

...the reference in putt training

Project:	Examples
Player:	Mr. Belly Putter
File:	Belly putter
Date:	16.10.2006

Path & Spot

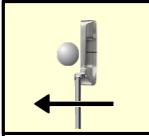

Top view

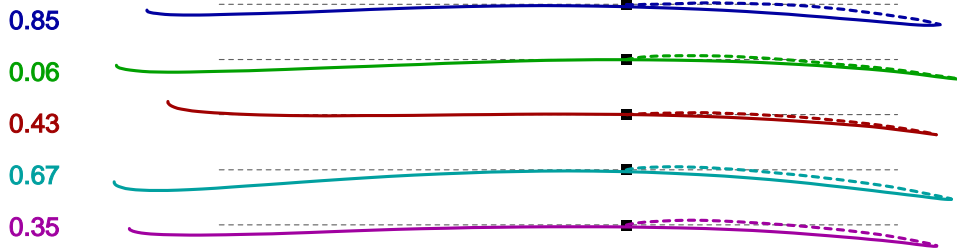

100 mm

0.5° right

Impact spot

-1.39
-0.19
0.50
-1.17
-1.68

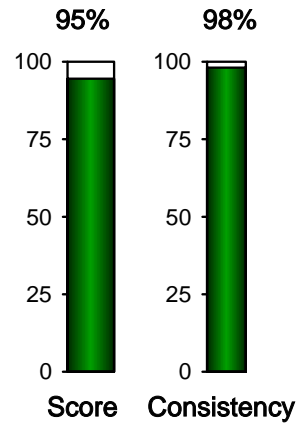
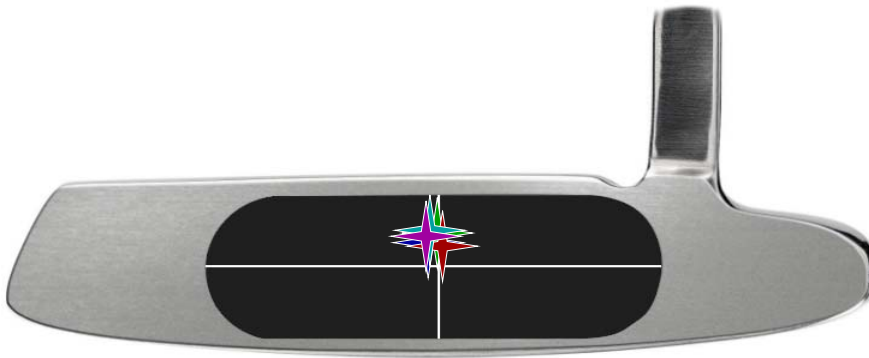

0.8 mm toe

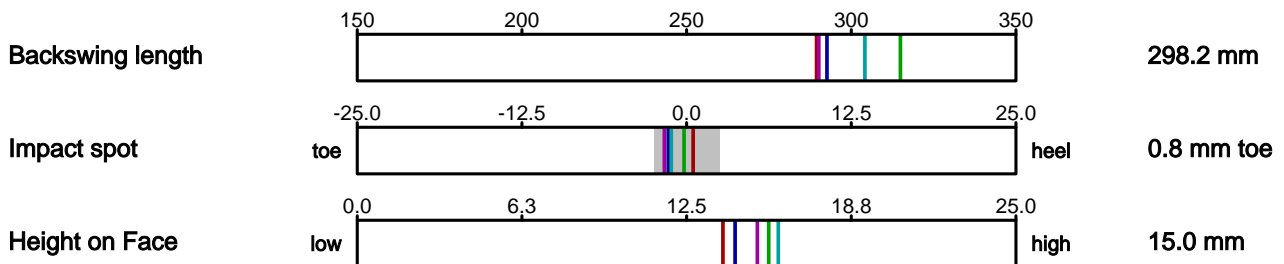



SAM PuttLab

...the reference in
putt training

Science&Motion
Sports

www.scienceandmotion.com

Project: Examples
Player: Mr. Belly Putter
File: Belly putter
Date: 16.10.2006

Loft & Rise

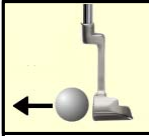

Side view

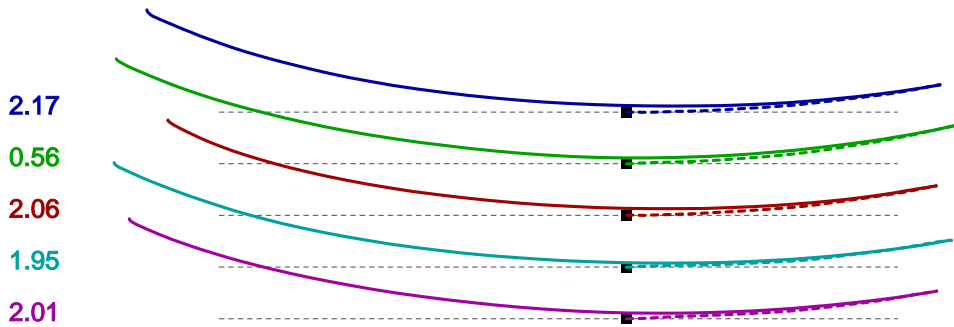

100 mm

1.8° up at impact

Launch & Spin

Predicted Launch: 2.8° up
Predicted Spin: neutral

Shaft angle: 0.1° addloft
(Putter Loft: 3.0°)

Rise angle: 1.8° up

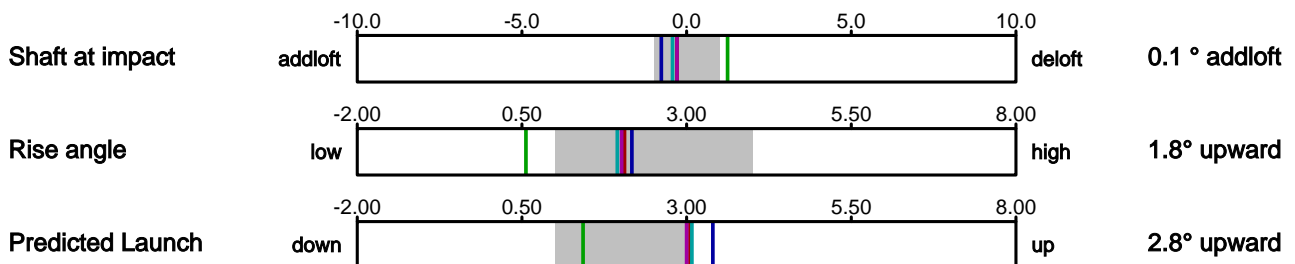
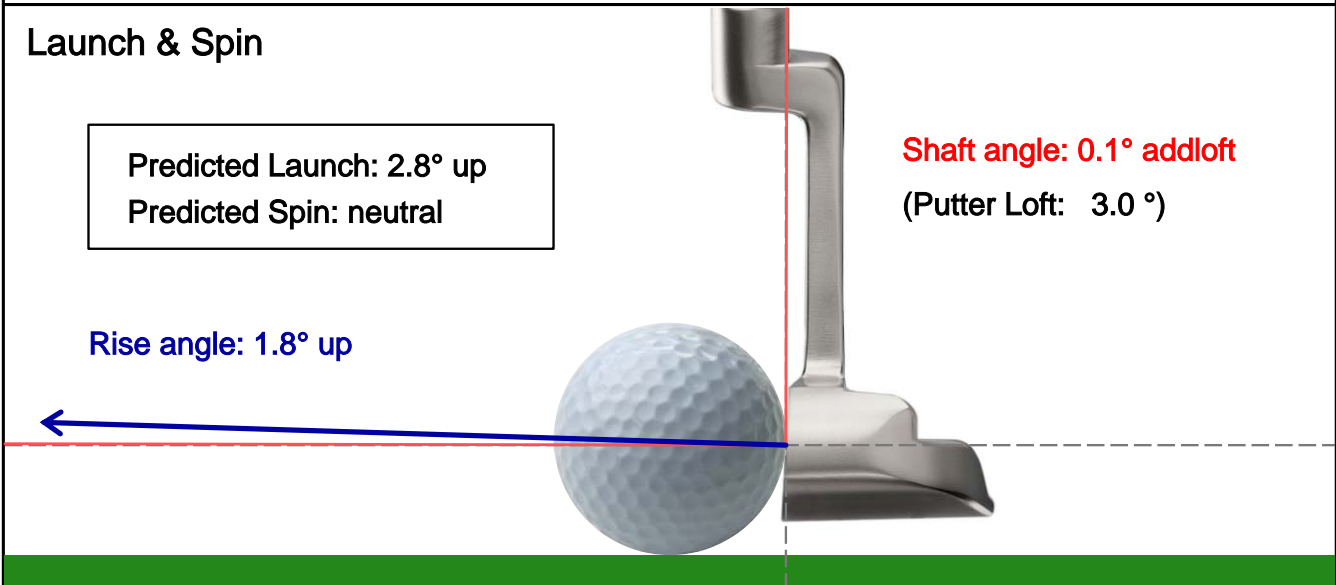



Project: Examples
 Player: Mr. Belly Putter
 File: Belly putter
 Date: 16.10.2006

Face Rotation

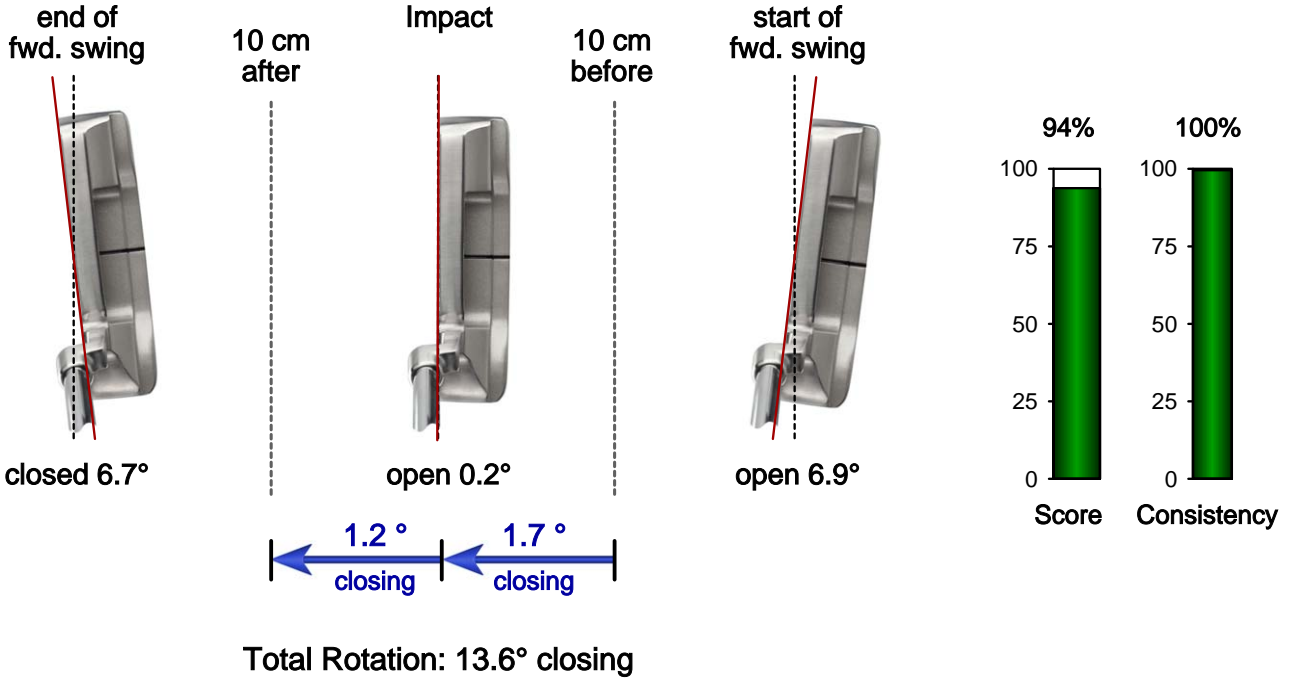

Face Angle

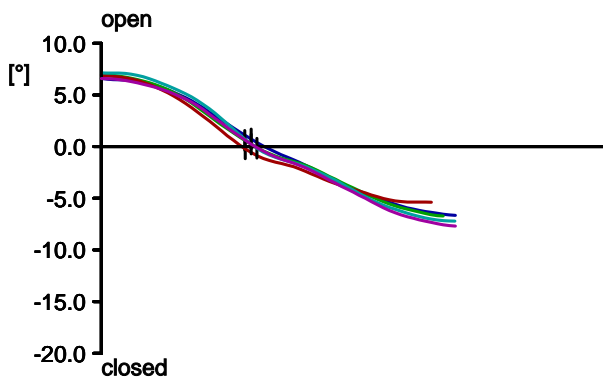

Rotation

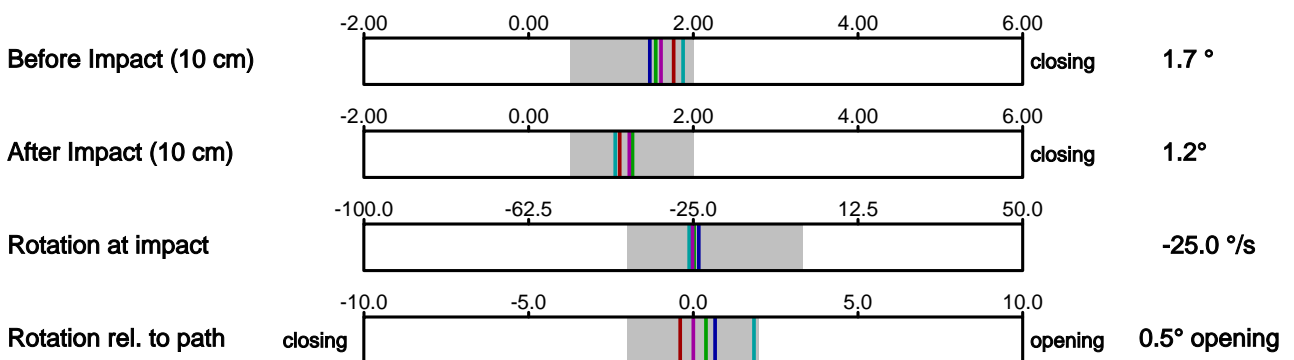
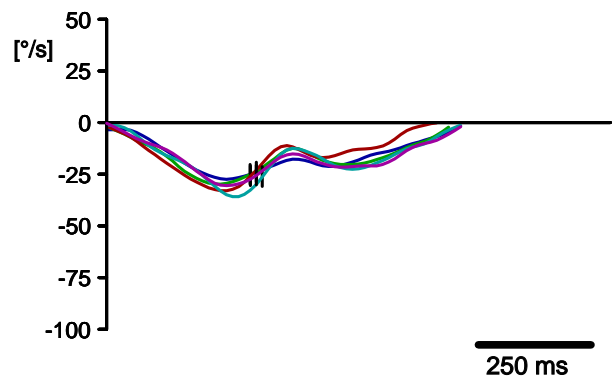



Project: Examples
 Player: Mr. Belly Putter
 File: Belly putter
 Date: 16.10.2006

Movement Dynamics

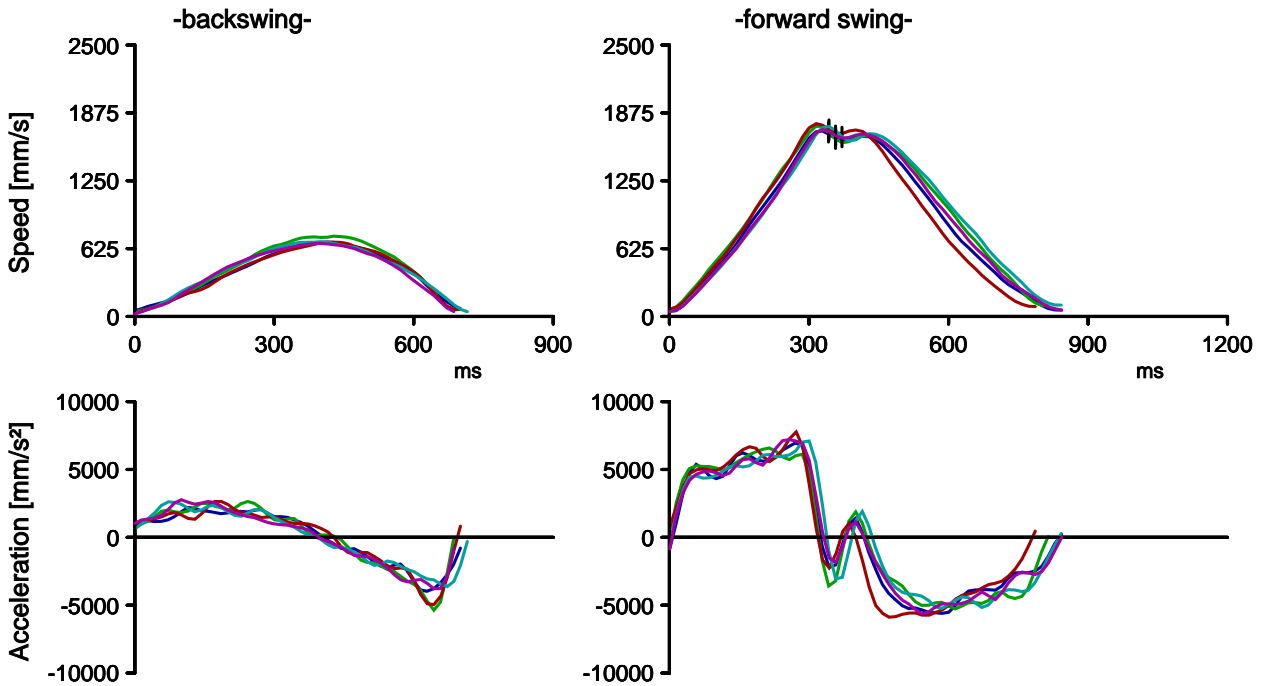

Timing

